

Lean-to Veranda

Installation Manual



Contents

- 3** **FIXING THE WALL PLATE**
- 4** **PREPARING THE GUTTER**
- 6** **PREPARING THE POSTS**
- 7** **FIXING POSTS TO GUTTER**
- 9** **FIXING THE GUTTER / POST ASSEMBLY IN POSITION**
- 10** **FIXING THE END BEAMS**
- 12** **FIXING THE INTERMEDIATE ROOF BEAMS**
- 14** **SECURING THE POSTS**
- 15** **FITTING THE RAINWATER DOWNPIPE**
- 17** **FITTING THE ROOF PANELS**
- 19** **FIXING THE GUTTER FASCIA**
- 20** **FIXING THE END COVER PLATES**
- 21** **CLEAN DOWN / TIDY UP**

1. FIXING THE WALL PLATE

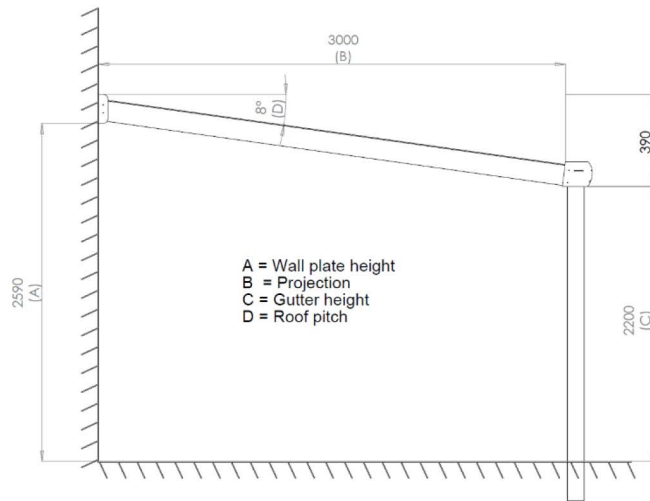

a) Measure & mark the wall plate height.

Referring to the project-specific CAD drawing provided, measure and mark the underside of the wall plate height on the wall that the veranda is to be fixed to.

(Dimensions shown on the diagram are for illustration purposes only)

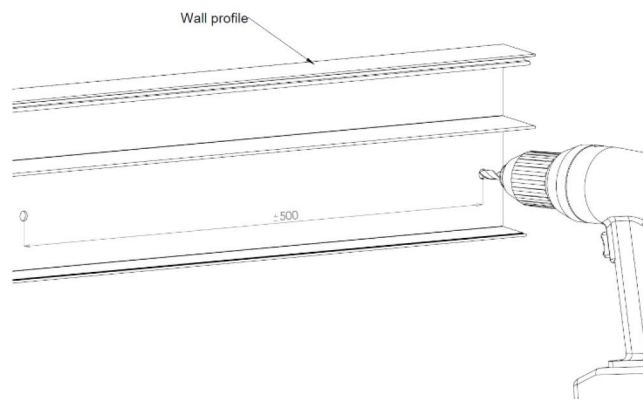

b) Pre-drill the wall plate.

Drill holes in the lower & upper section of the wall plate approx. 500mm apart. Use a drill bit size that is compatible with the specific fixings you are using. The type of fixing you use depends on the substrate you are fixing to.

c) Fix the wall plate in position

Offer up the wall plate into its exact position on the wall and drill holes into the wall through the pre-drilled holes in the wall plate. Using the fixings you have chosen, securely fix the wall plate to the wall.

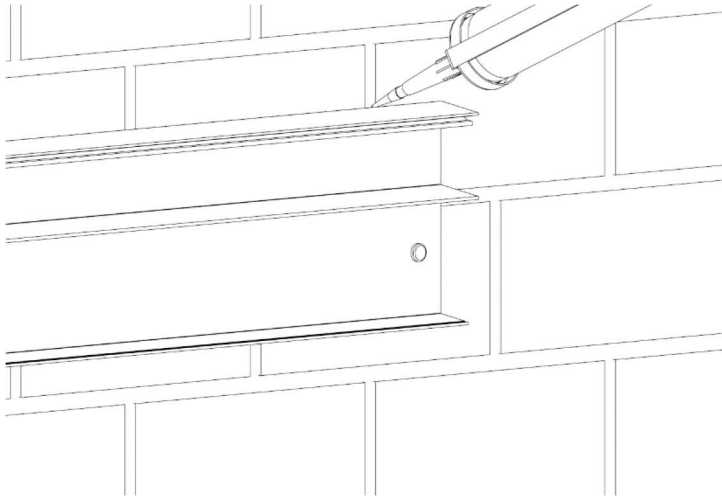

d) Seal the joint between the wall plate and the wall

Seal the wall plate profile against the wall using exterior grade mastic, ensuring all surfaces are dust-free and dry. Smooth the mastic to create a water-tight seal and remove any excess.

2. PREPARING THE GUTTER

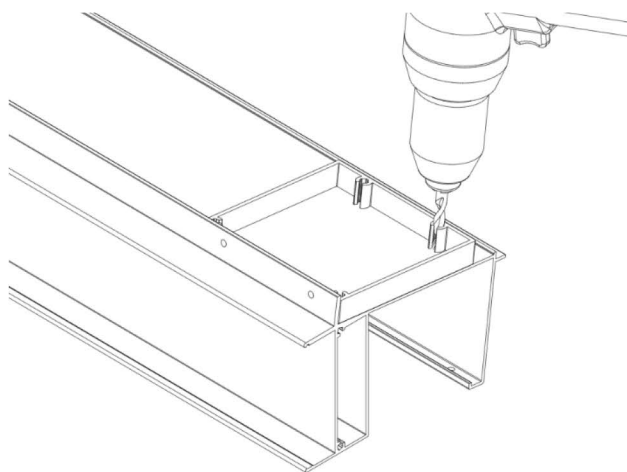

a) Drill pilot holes for posts.

Using the template profiles provided drill pilot holes with 1.5-2mm drill bit in the base of the gutter wherever a post is to be fixed.

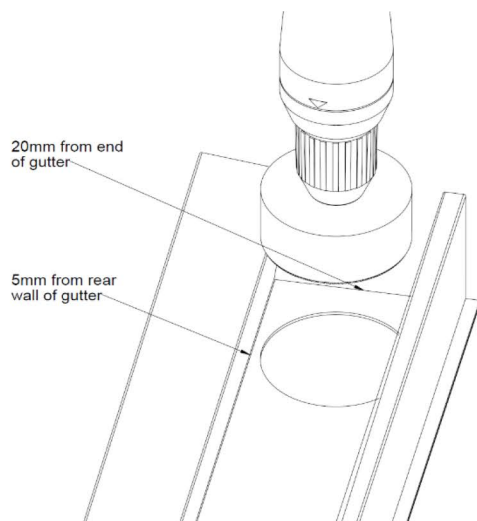

b) Cut hole for down pipe.

Decide which end of the gutter the rainwater outlet will be positioned, drill an arbour hole in the base of the gutter using a 62mm hole saw. The edge of the hole must be approx. 5mm from the rear wall of the gutter and 15-20mm from the end.

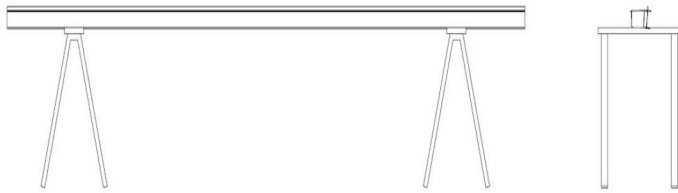

c) Fit steel reinforcing bar if required.

Place the gutter *up-side-down* on a pair of trestles.

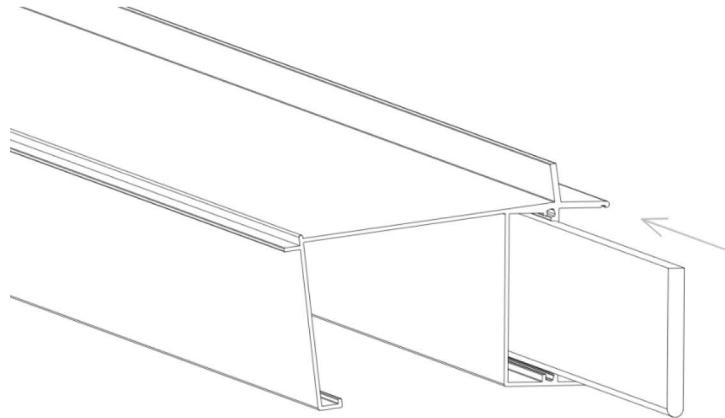

Slide the steel bar into the cavity at the back of the gutter.

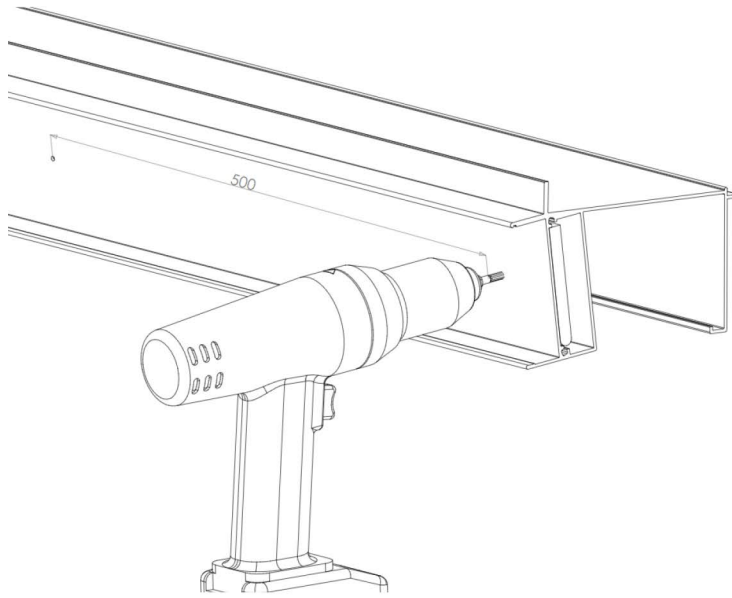

Pre-drill a 3mm hole through the back of the gutter into the steel bar at approx. 500mm intervals along the length of the gutter. Be careful not to pierce the inside wall of the gutter.

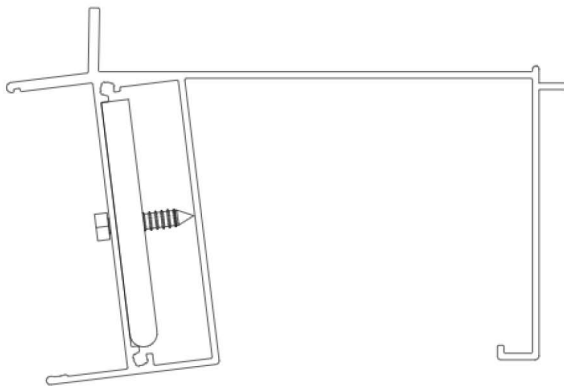

Fix the steel bar into position with drill screws no more than 20mm in length

3. PREPARING THE POSTS

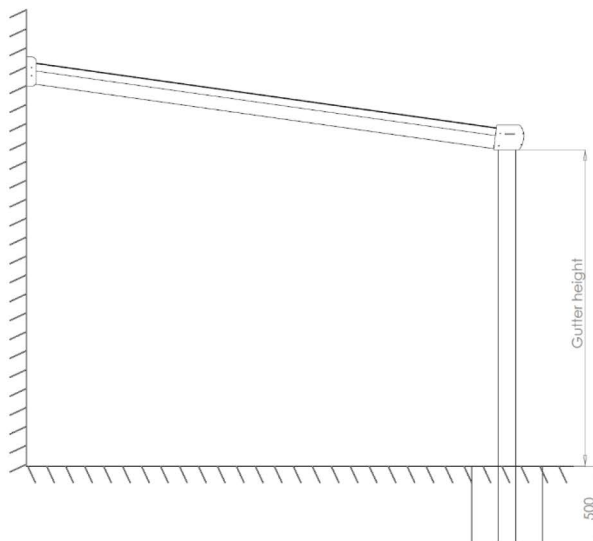

a) Cut the posts to size (if necessary)

The post supplied are 3000mm in length. If posts are being cast in concrete, they should be set into the ground at least 500mm. If the posts are being surface fixed, they should be cut to the gutter height stated on the CAD drawing.

4. FIXING POSTS TO GUTTER

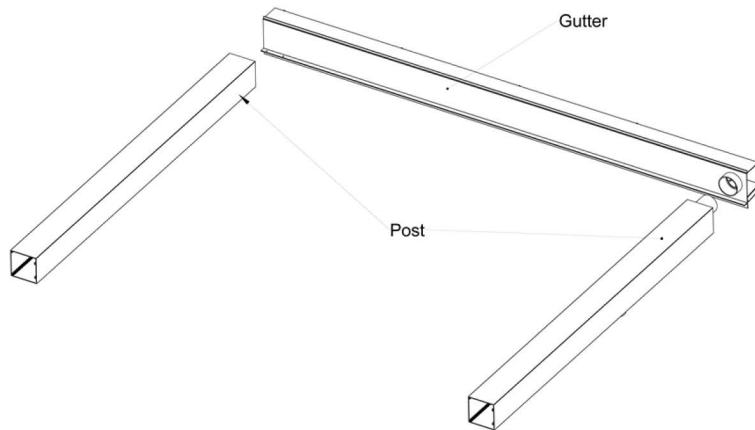

a) Layout posts and gutter of the ground

Lie the posts down on a clear, flat surface and place the gutter in position.

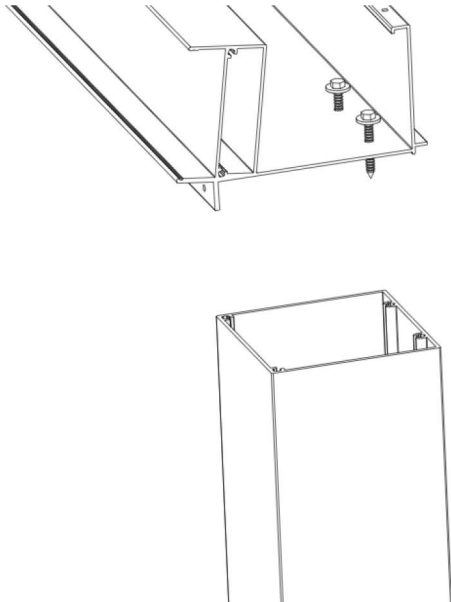

b) Fix the posts to the gutter.

Ensure the screw hole lugs in the top of the post line up with the holes you have drilled in the base of the gutter. Using 5.5 x 55mm hex head screws with neoprene washers, fix the base of the gutter to the top of the posts.

Using 5.5 x 32 hex head screws, fix the lip at the back of the gutter into the back face of the post

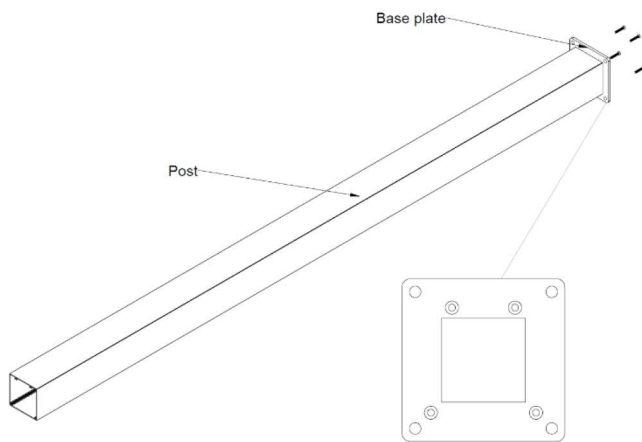
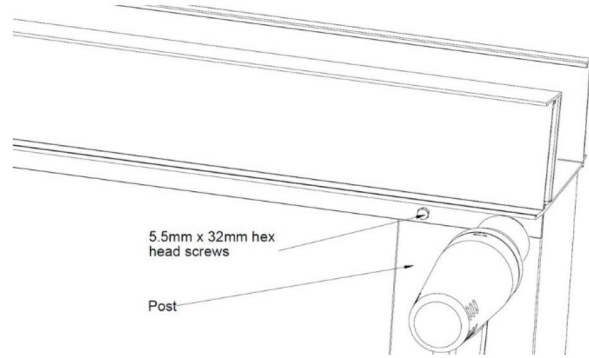
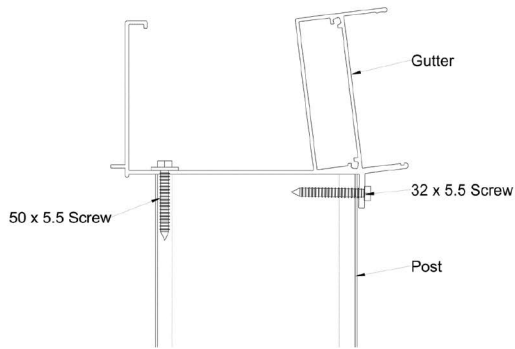

c) Fix standard base plates – if surface mounting with standard base plates or securing below ground.

Using the 5.5 x 50 CSK screws provided, fix a base plate to the bottom of each post.

5. FIXING THE GUTTER/POST ASSEMBLY IN POSITION

a) Measure and mark out post positions

Measure the wall-to-inside-of-post dimension as shown on the CAD drawing and mark position.

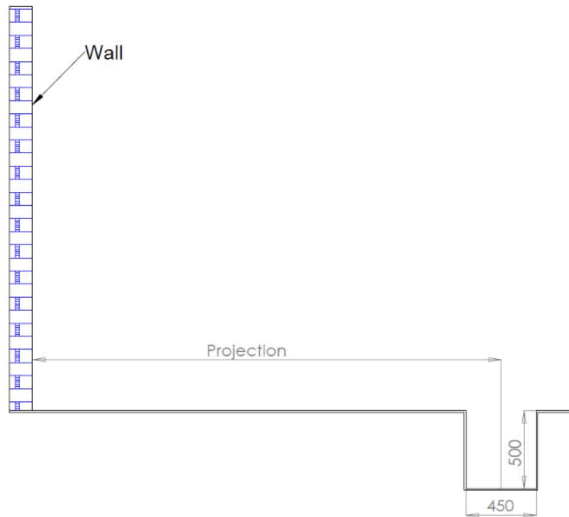

b) Preparation

Securing below ground

Dig a footing for each post approx. 500 x 500 x 500mm

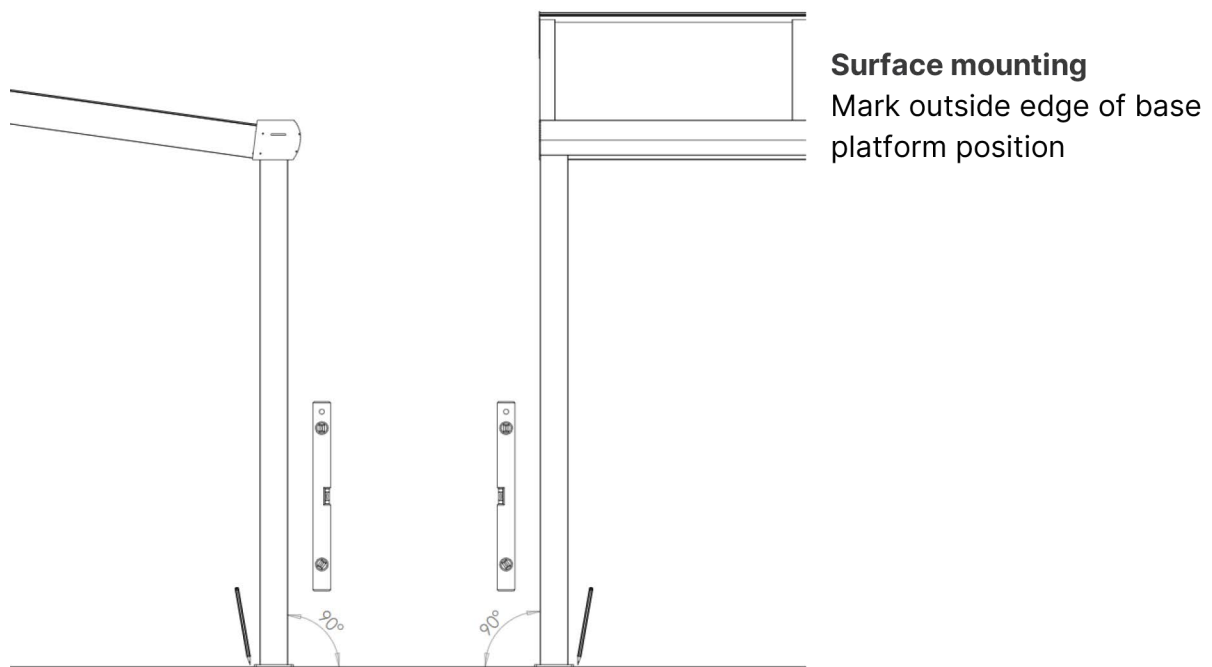

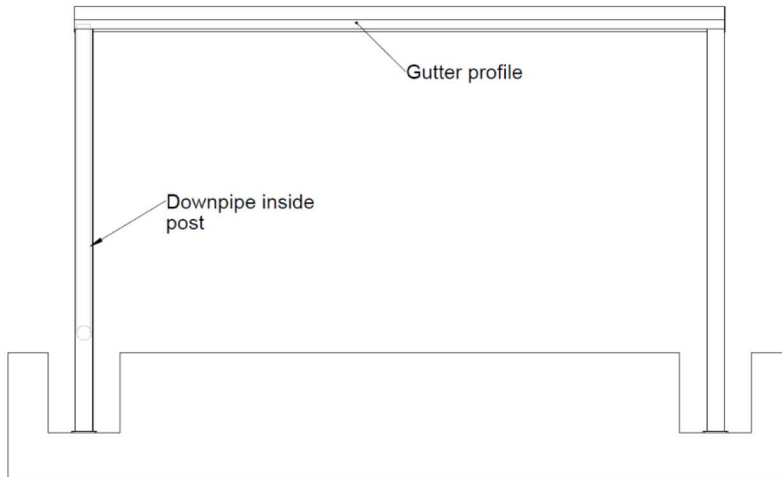

c) Place gutter/post assembly in position

Lift up the gutter/post assembly from the floor and place it in position ensuring the back of the gutter is facing the wall plate. Do not secure the posts in place yet, use temporary props if necessary to hold them vertical.

Check the gutter height is correct according to the CAD drawing.

6. FIXING THE TWO END ROOF BEAMS

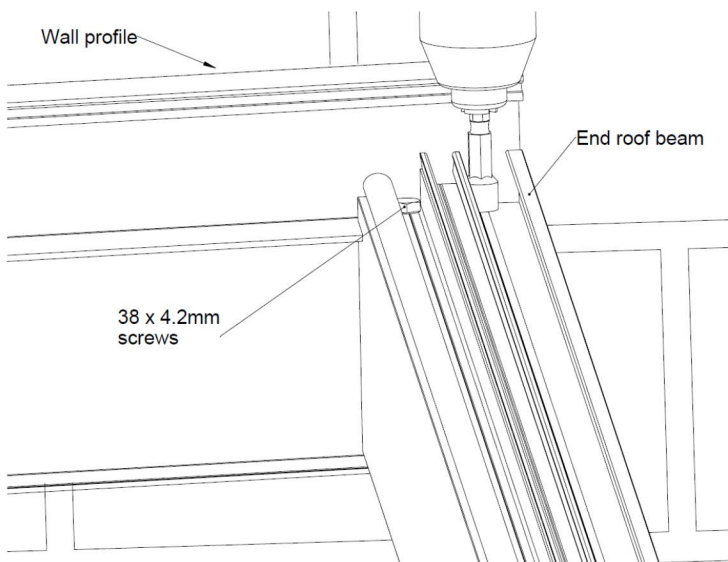

a) Fix one of the end roof beams to the wall plate

Slide one of the side roof beams into the wall plate profile. Push the beam into the wall plate profile as far as possible and secure with a 38 x 4.2mm drill screw.

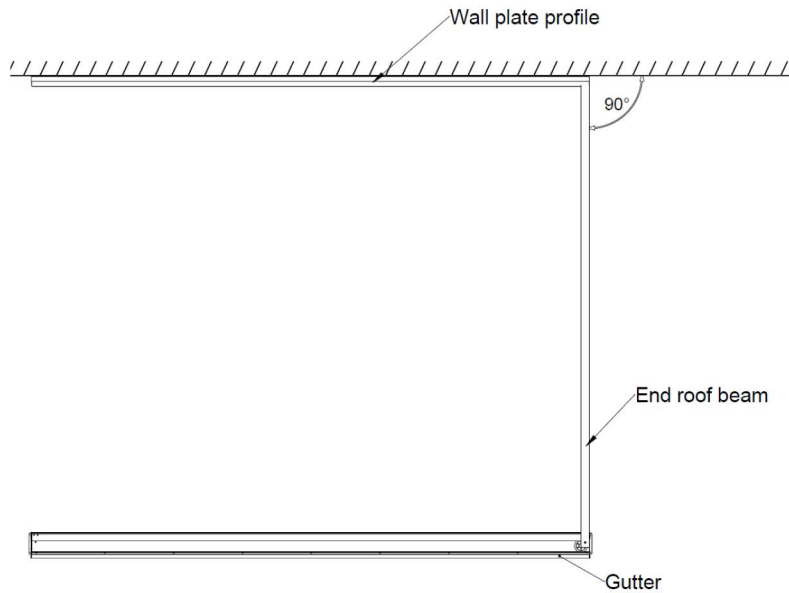

b) Ensure the roof beam is positioned squarely

Using a laser or large set square, ensure that the roof beam is at 90 degrees to the wall plate profile, and 90 degrees to the gutter profile.

c) Fix the side roof beam to the gutter

Once square, fix the front end of the side roof beam to the back of the gutter using 2 x 38 x 4.2mm drill screws.

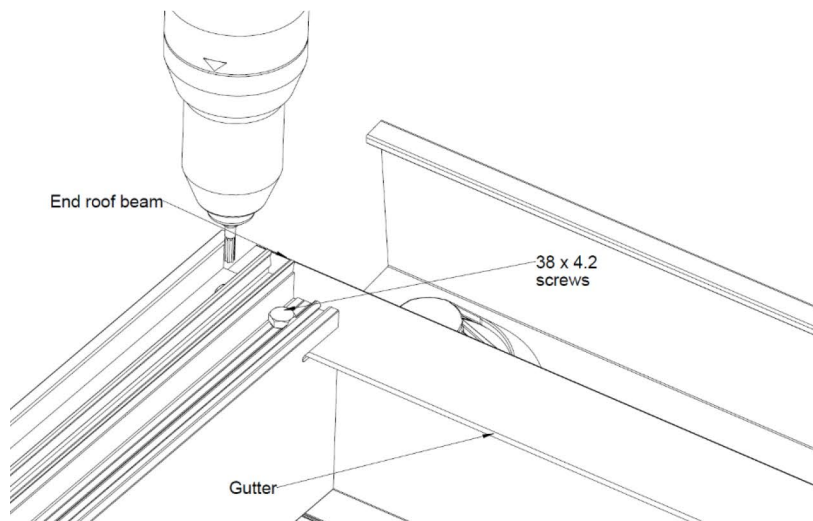

d) Fix the side roof beam to the opposite end of the veranda

Repeat the above steps for other side roof beam. The gutter/post assembly should now be self-supporting, so any temporary props can be removed.

7. FIXING THE INTERMEDIATE ROOF BEAMS

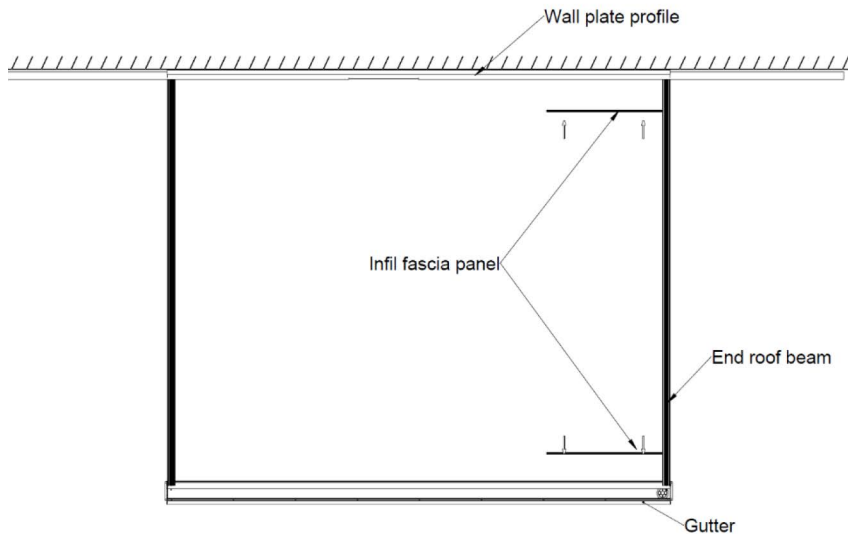

a) Use the infill fascia panels to space the roof beams correctly.

The infill fascia panels have been pre-cut to size. Clip an infill fascia into both the wall plate and the back of the gutter adjacent to one of the end roof beams.

b) Place all intermediate roof beams in position

Lift the first intermediate roof beam into position, ensuring it is located as close as possible to the infill fascia panels you have just installed. Put the next infill fascia panels in position, and then the next roof beam. Repeat this process until all infill fascia panels and roof beams are in place.



IMPORTANT!

Do not fix roof beams into position until all infill fascia panels, and roof beams are equally spaced along the length of the roof.

Due to 1mm tolerance in the factory, and variables on site, sometimes the last set of infill fascia panels may seem too short or too long. If this is the case the space should be recued or gained by a slight adjustment in the position of the other roof beams.

c) Fix roof beams in position.

Once all infill fascia panels and roof beams are equally spaced, secure each roof beam at both ends using 2 No. 38 x 4.2mm drill screws, fixed either side of the centre of the roof beam.

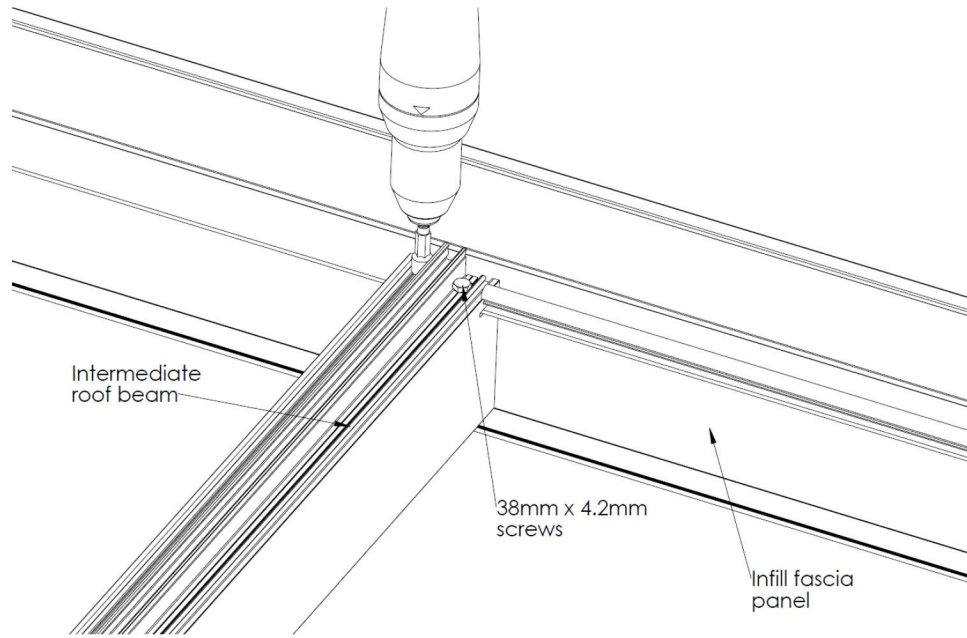

8. SECURING THE POSTS

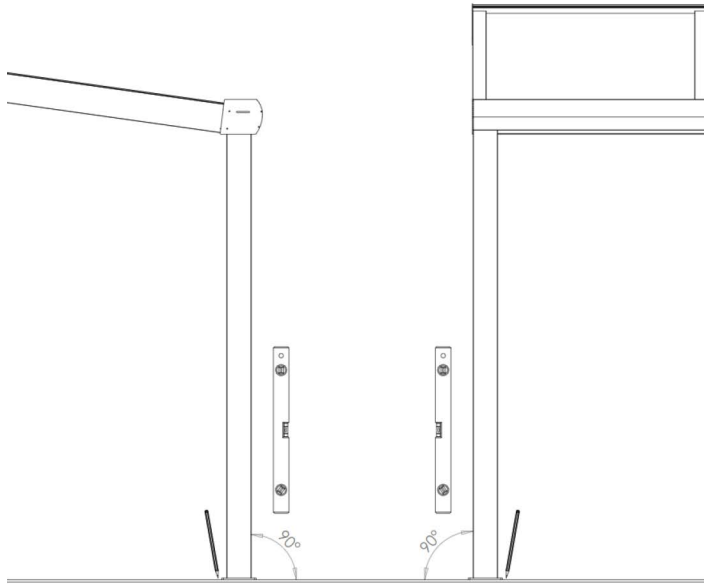

Once the roof beams are installed, check again that the veranda is installed at 90 degrees to the wall using a laser, or large set square. Then, using a spirit level check that the posts are vertical in both directions.

Secured below ground

Fill the hole around the post with quick-set concrete, compacting at regular intervals, continuously checking that the post remains vertical.

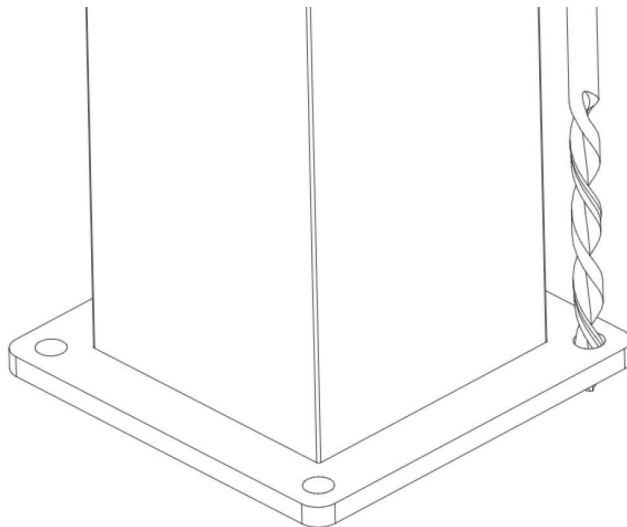

Surface mounted

Mark the hole locations, drill into the floor substrate using a drill bit to suit your fixing diameter, depth and type. Secure fixings.

9. FITTING THE RAINWATER DOWNPIPE

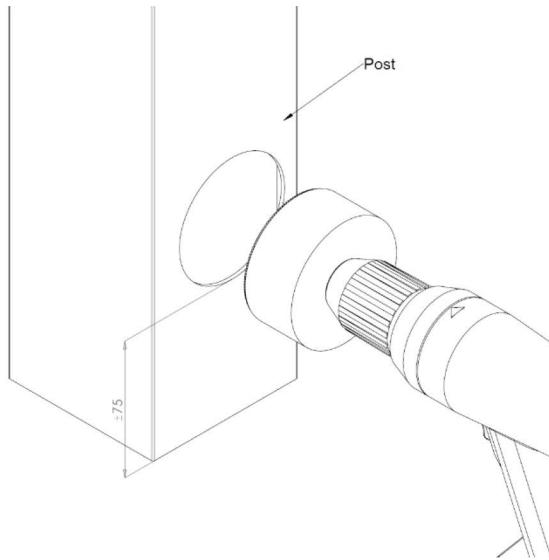

a) Cut hole in post for rainwater outlet.

Cut a hole in the post that is to house the plastic down-pipe just above ground level using a 62mm arbour.

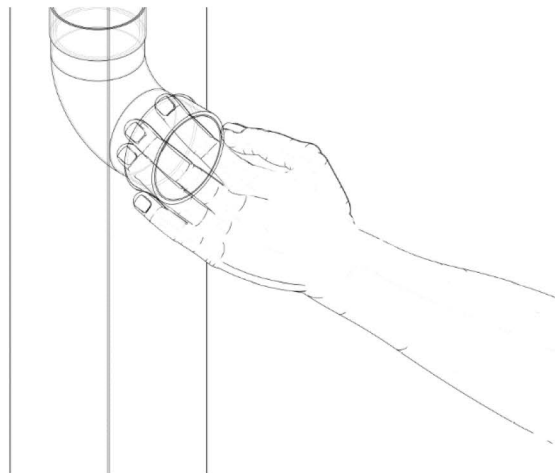

b) Insert the pipe into the post and connect elbow (requires 2 persons)

Measure the distance from the gutter to the outlet hole just drilled and cut the downpipe to the correct length. Lower the downpipe into the post through the hole in the base of

the gutter. Hold the elbow in place inside the post at the bottom and locate it into the bottom of the post.

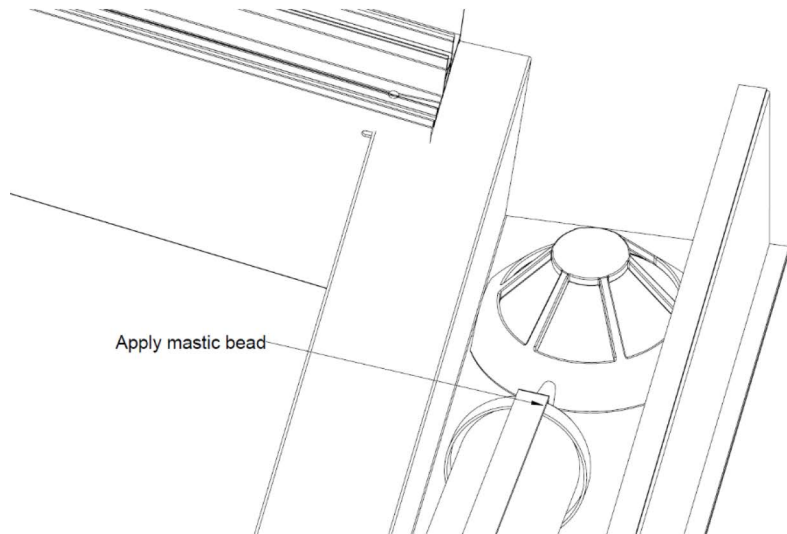

c) Insert the leaf catcher

Place the leaf catcher through the hole in the base of the gutter and into the downpipe ensuring a good mastic bead is applied to seal the leaf catcher in place.

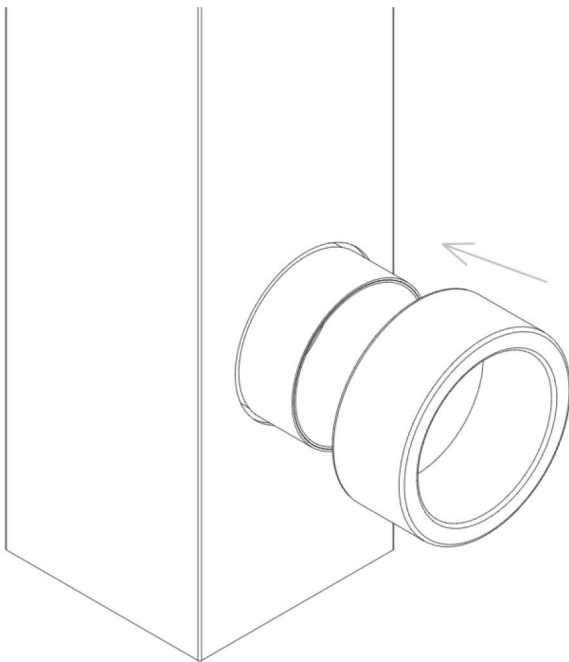

d) Fix the elbow outlet cover

Fix the plastic outlet cover over the exposed elbow end at the base of the post, Fix in place with mastic.

10. FITTING THE ROOF PANELS



IMPORTANT!

Gloves and arm protectors to cut level 5 must be worn. This step requires 2, but ideally 3 persons. Wherever possible, glass should be carried on its edge. As the glass is laid 'flat' onto the roof beams ensure it is supported from underneath to reduce the risk of the glass cracking under its' own weight.

a) Place the first glass panel into position.

Starting at one end and ensuring that the polished edge is at the gutter end, lay the first panel between the end roof beam and the adjacent intermediate roof beam.

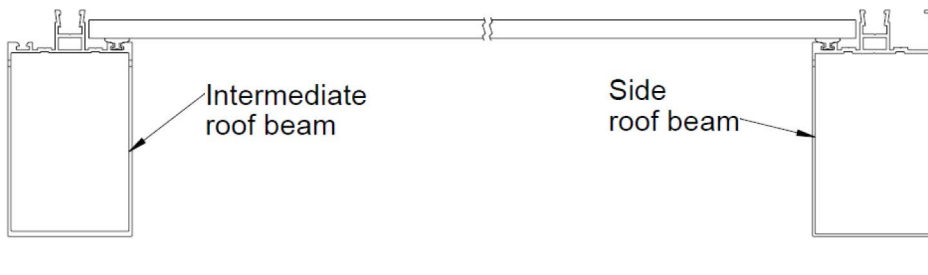

The glass should be pushed against the wall profile so that it overhangs into the gutter by approx. 50mm

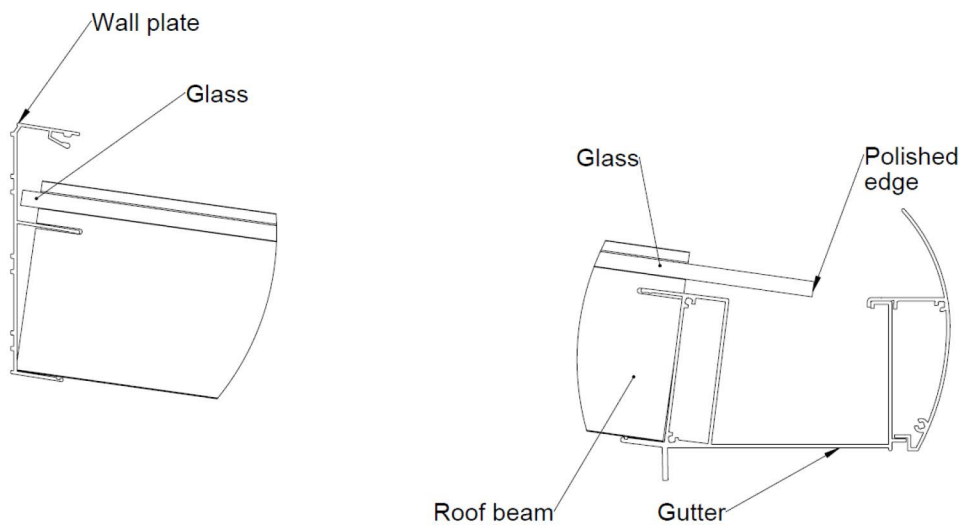

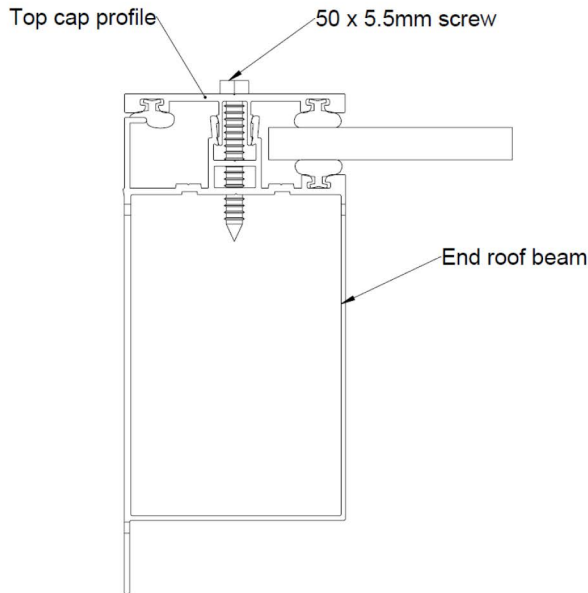

b) Fix the top cap profile to the first end roof beam

Place a top cap profile on top of the end roof beam, ensuring the two 'prongs' in the underside of the top cap profile are located inside the open channel in the centre of the roof beam. Push or tap with a rubber mallet until the top cap profile clicks into place. Fix the top cap into the roof beam using 5.5 x 50mm Hex head with neoprene washers at approx. 500mm intervals.

c) Start fitting the rubber wall plate gasket.

Starting at the end of the wall plate above the end roof beam top cap just fitted, push the rubber gasket into the corresponding groove on the wall plate. Work your way along, pushing the rubber gasket in place above the glass panel. Leave the rubber gasket rolled up on top of the glass and wait until the next glass panel and top cap profile are installed before continuing.

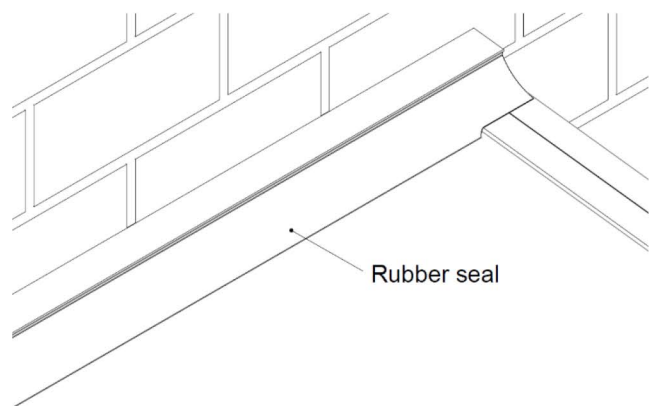
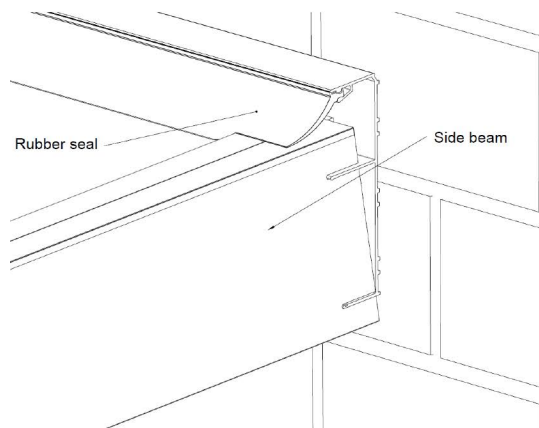

d) Fix the remaining glass panels, top caps and wall plate rubber gasket

Lay the next glass panel in place, insert the next top cap profile into the first intermediate roof beam and fix with 5.5 x 50mm hex head screws with neoprene washers. Continue pushing in the wall plate rubber gasket above the glass panels.

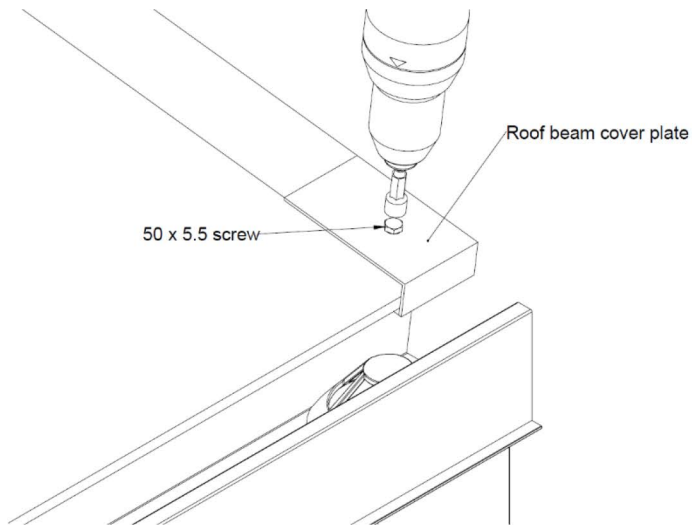

e) Fix the roof beam end cover plates

Using 5.5 x 50mm hex head screws with neoprene washer, fix the L plates to the end of each top cap profile

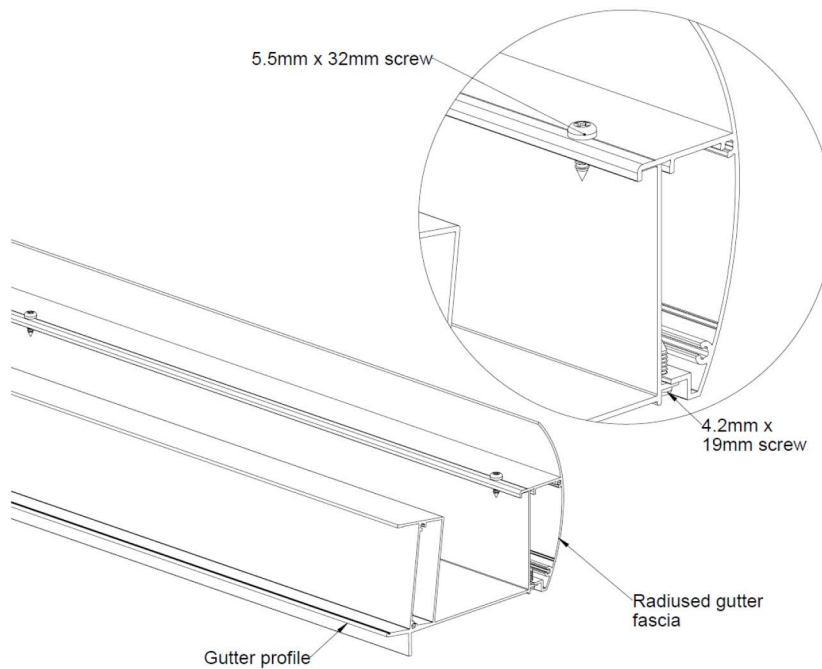

11. FIXING THE GUTTER FASCIA

Place the gutter fascia onto the front of the gutter by hooking the fascia into place and fixing with 5.5 x 32 hex head screws spaced at approx. 1000mm intervals. Fix the fascia into the underside of the gutter with 4.2 x 19mm screws at approx. 1000mm intervals.

12. FIXING THE END COVER PLATES

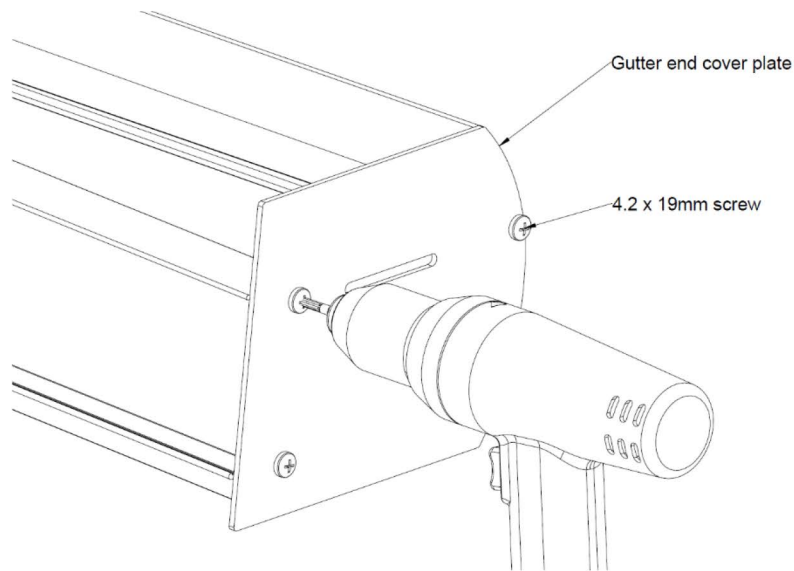

a) Fix the gutter end cover plates.

Secure the gutter end plates to each end of the gutter using 4.2 x 19mm screws. Apply a mastic bead around the inside edge of the gutter end cover plate to ensure a watertight seal.

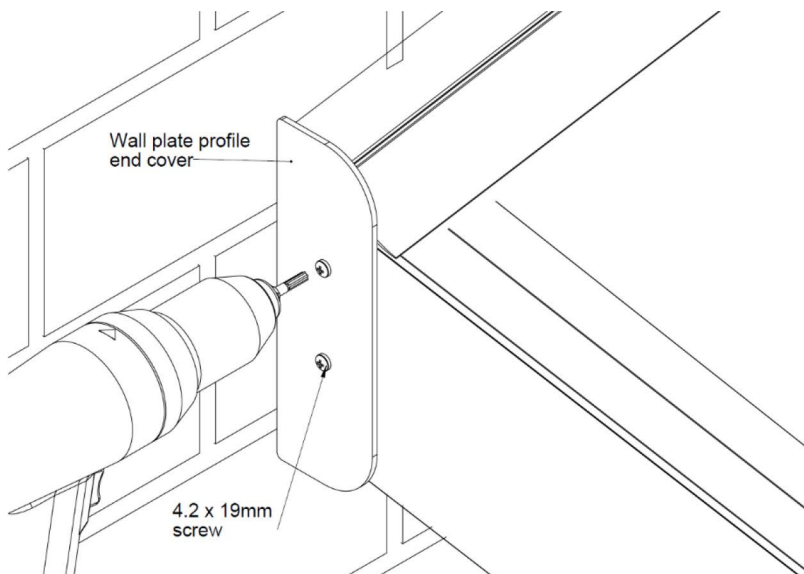

b) Fix the wall plate profile end cover plates.

Fit the wall plate profile end cover plates to each end of the wall plate profile using 2 No. 4.2 x 19mm drill screws.

13. CLEAN DOWN / TIDY UP

a) Wipe down profiles.

Remove dust/finger marks from the aluminium profiles by wiping down with a damp cloth.

b) Wipe down profiles.

Once the mastic in the gutter has set, hose down the glass on the outside and wipe down with cloth from the inside to remove finger marks.